



TDS BLOWDOWN CONTROL VALVES VPC26

DESCRIPTION

When a steam boiler is in operation there is continuous evaporation of boiler water which causes an undesirable increase in TDS (Total Dissolved Solids) concentration. A typical problem that results from this is water foaming, which leads to reduced boiler performance and wet steam. Furthermore, dissolved and suspended solids will carry over into the steam lines, contaminating valves, tubes, heat exchangers and steam traps, leading to corrosion, scaling and erosion. For these reasons, a certain amount of boiler water must be discharged continuously or periodically to ensure TDS concentration is kept within the recommended parameters.

The ADCATrol VPC26 is a control valve specially designed for this purpose and features a multi-stage trim to progressively reduce the energy of the fluid. This makes it ideal for discharge of boiler blowdown at high differential pressures where flashing is a concern.

The valve is suitable for both continuous and on/off TDS control via a PA series reverse action pneumatic actuator or AV series fail-safe spring return actuator.

MAIN FEATURES

- Minimized vibrations due to continuous stem guiding.
- Seat and plug sealing surfaces are protected from erosion at low stroke positions.
- Compact and modular design.
- Multi stage trim for controlled velocity and pressure drop.
- Hardened stainless steel trim with stellite faced plug and seat.
- Tool-free quick exchangeable clamped-in seats, allowing fast and easy inline maintenance procedures.

OPTIONS AND

- ACCESSORIES:**
- Sample valve bottom connection.
 - NV400B sample valve.
 - Blowdown controllers.
 - TDS probes.

- USE:**
- TDS blowdown control in steam boilers and other applications with high pressure drops and low flow rates where cavitation and flashing phenomenon are likely to occur.

AVAILABLE

- MODELS:**
- VPC26S – carbon steel.
 - VPC26i – stainless steel.

- SIZES:**
- 1/2" to 1 1/2"; DN 15 to DN 40.

- CONNECTIONS:**
- Flanged EN 1092-1 PN 40.
 - Flanged ASME B16.5 Class 300.

AVAILABLE

- ACTUATORS:**
- PA10 linear pneumatic actuator.
 - AVF234S linear electric actuator.

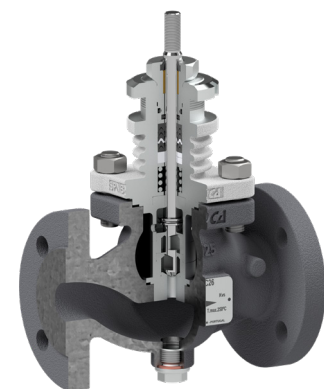

CE MARKING – GROUP 2 (PED – European Directive)	
PN 40	Category
1/2" to 1" – DN 15 to 25	SEP
1 1/2" – DN 40	1 (CE marked)

BODY LIMITING CONDITIONS					
VPC26S				VPC26i	
FLANGED PN 40 *		FLANGED CLASS 300 **		FLANGED PN 40 *	
ALLOWABLE PRESSURE	RELATED TEMPERATURE	ALLOWABLE PRESSURE	RELATED TEMPERATURE	ALLOWABLE PRESSURE	RELATED TEMPERATURE
40 bar	-10 / 50 °C	50 bar	-10 / 50 °C	40 bar	-10 °C / 50 °C
33,3 bar	200 °C	43,9 bar	200 °C	33,7 bar	200 °C
27,6 bar	300 °C	36,9 bar	350 °C	29,7 bar	300 °C
25,7 bar	350 °C	34,6 bar	400 °C	28,5 bar	350 °C
23,8 bar	400 °C	–	–	27,4 bar	400 °C

* Rating according to EN 1092-1:2018; ** Rating according to EN 1759-1:2004.

STEM SEALING

PTFE/GR V-RINGS (V1.2)

-10 to 250 °C

FLOW RATE COEFFICIENTS (m³/h)				
SIZE	1/2" DN 15	3/4" DN 20	1" DN 25	1 1/2" DN 40
Kvs	1,2	1,2	1,2	1,8
STROKE	6			8

For conversion Kvs = Cv (US) x 0,865.

DIMENSIONS

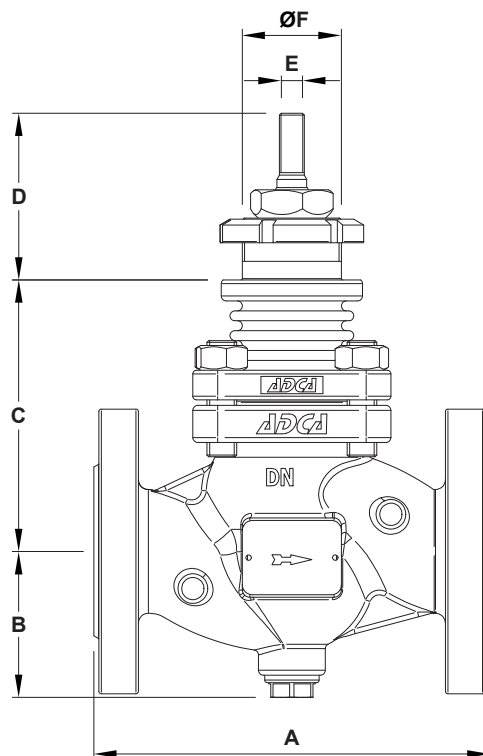

DIMENSIONS (mm)					
DIMENSION	SIZE				
	1/2" – DN 15	3/4" – DN 20	1" – DN 25	1 1/2" – DN 40	
A	EN	130	150	160	200
	ASME	190 *	194 *	197	235
B		61	61	61	75
C		104	104	109	193
D		70	70	70	70
E		M10 x 1			
ØF		M40 x 1,5			
G **		3/8"			

* With welded-on flanges.

** As standard, in versions with EN flanges, this connection is female threaded ISO 228. In versions with ASME flanges, this connection is female threaded NPT.

WEIGHTS (kg)				
	SIZE			
	1/2" – DN 15	3/4" – DN 20	1" – DN 25	1 1/2" – DN 40
EN	5,3	6,1	6,9	12,6
ASME	5,3	6,2	7,4	13,8

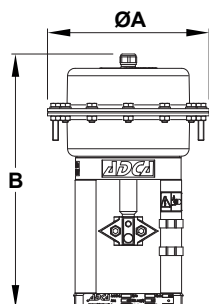

DIMENSIONS – PA SERIES PNEUMATIC ACTUATORS (mm)	
DIMENSION	PA10
ØA	170
B	251
WEIGHT (kg)	6,3

For more information, please consult IS 3.05 – PA Linear pneumatic actuators.

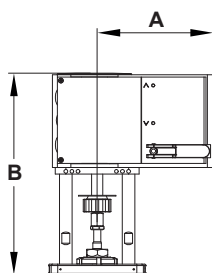

DIMENSIONS – AV SERIES ELECTRIC ACTUATORS (mm)	
DIMENSION	AVF234S
A	166
B	289
WEIGHT (kg)	4,1

For more information, please consult IS 3.74 – AVM234S-AVF234S Linear electric actuators.

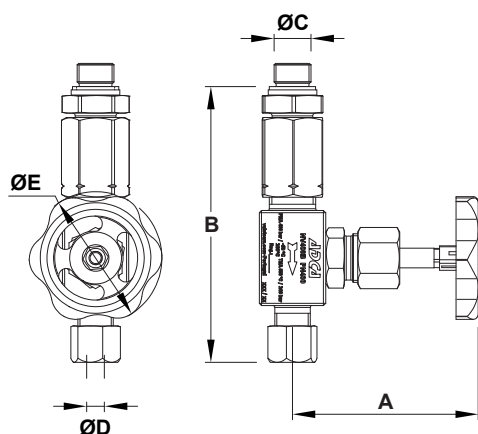

DIMENSIONS – NV400B SAMPLE VALVE (mm)	
DIMENSION	NV400B
A	90 (maximum)
B	125
ØC	3/8"
ØD	8
ØE	60
WEIGHT (kg)	0,63

For more information, please consult IS 4.90 – NV400 Needle valves.

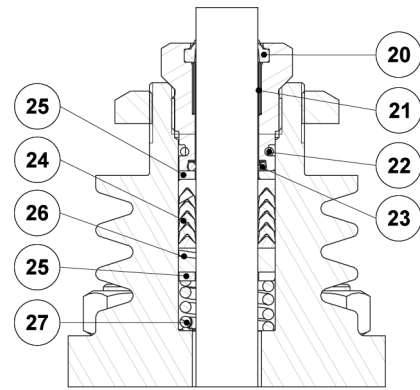
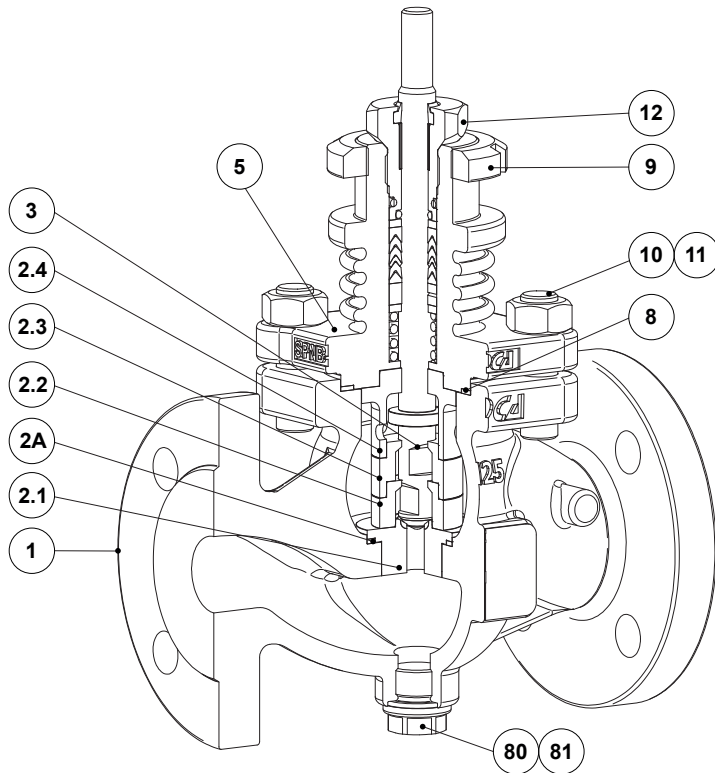

PTFE/GR V-Rings (V1.2)

MATERIALS		
POS. N°	DESIGNATION	MATERIAL
1	Valve body (VPC26S)	A216 WCB / 1.0619
	Valve body (VPC26i)	A351 CF8M / 1.4408
2A	* Seat gasket	Stainless steel / Graphite
2.1	* Seat	AISI 316L / 1.4404 stellite faced
2.2	Lower guide sleeve	Hardened stainless steel
2.3	Intermediate guide sleeve	Hardened stainless steel
2.4	Upper guide sleeve	Hardened stainless steel
3	* Valve plug	AISI 316L / 1.4404 stellite faced
5	Bonnet	A351 CF8 / 1.4308
8	* Gasket	Stainless steel / Graphite
9	Actuator lock nut	A351 CF8 / 1.4308
10	Nuts (VPC26S)	EN 10269 steel
	Nuts (VPC26i)	Stainless steel A2-70
11	Studs (VPC26S)	EN 10269 steel
	Studs (VPC26i)	Stainless steel A2-70
12	Packing nut	AISI 303 / 1.4305
20	* Scraper ring	Viton; NBR
21	* Plain bearing	Bronze / PTFE
22	* O-ring	EPDM
23	* O-ring	Viton
24	* Chevron packing set	PTFE; Graphite filled PTFE
25	Washer	AISI 304 / 1.4301
26	Stem guide	Stainless steel filled PTFE
27	* Spring	AISI 302 / 1.4300
80	* Gasket	Copper
81	Plug	AISI 316 / 1.4401

* Available spare parts.

ORDERING CODES VPC26 a)										
Valve model	VPC26	1	S	XX	1	A3	N	15		
TDS blowdown control valve, two way, straight body	VPC26									
Valve series										
Series 1		1								
Body material										
A216 WCB / 1.0619 carbon steel			S							
A351 CF8M / 1.4408 stainless steel			I							
Versions										
Valve without sample valve bottom connection				XX						
Valve with sample valve bottom connection and plug				BX						
Stem sealing										
PTFE/GR V-Rings (V1.2)					1					
Flow rate coefficient										
Kvs 1,2 (available only for 1/2" to 1" and DN 15 to DN 25)						A3				
Kvs 1,8 (available only for 1 1/2" and DN 40)						A4				
Pipe connection										
Flanged EN 1092-1 PN 40							N			
Flanged ASME B16.5 Class 300							V			
Size										
1/2" or DN 15									15	
3/4" or DN 20									20	
1" or DN 25									25	
1 1/2" or DN 40									40	
Special construction / Additional points										
Full description or additional codes have to be added in case of a non-standard combination										E

a) Codification for valve only. For actuator codes, refer to the appropriate information sheet.